

# Avia Decals

in association with



# AVD144-12

1/144 scale Decal Set  
3 paint variants

Designed for Zvezda model kit #7012

## Boeing 777-300ER

Paint Masks  
included

*Air China, China Eastern Airlines, Korean Air Lines*

Technical stenciling and paint mask included

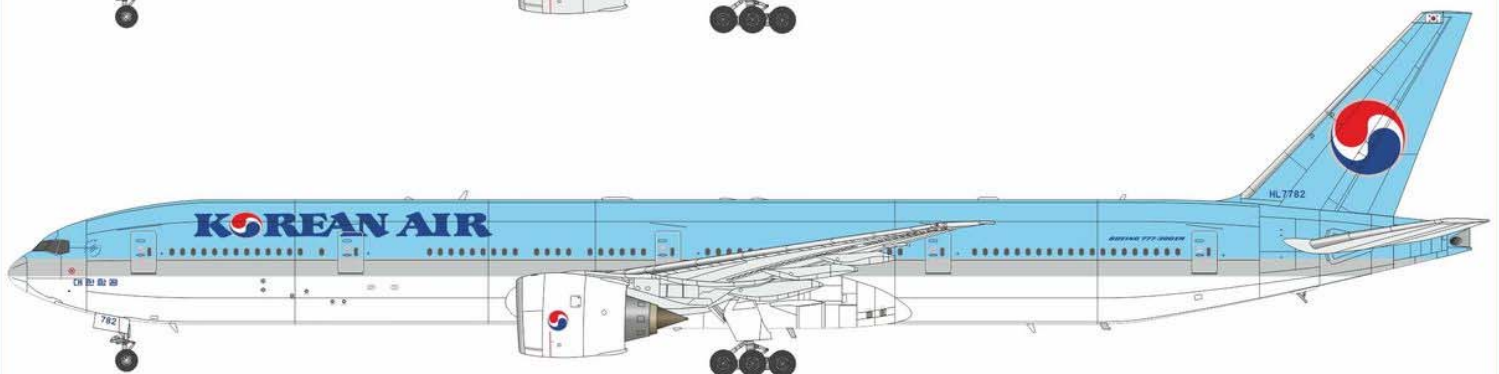
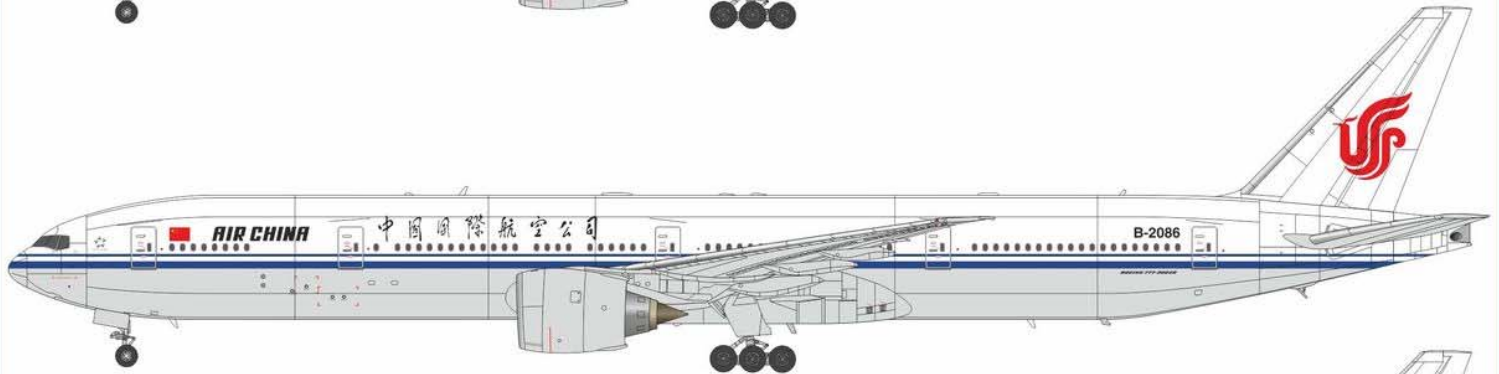

*Decal Design, Logo and Cover Design is a property of AviaDecals and its affiliates.*

AviaDecals ©, 2016

[www.aviadecals.com](http://www.aviadecals.com)

Decal set for Boeing 777-300ER model in 1/144 scale. Designed for Zvezda model kit #7012

This decals set gives you the ability to paint model in one of three variants (with several registrations) and contains decals and paint masks.

You can download this printable manual (PDF file, A4 size) at [www.aviadecals.com](http://www.aviadecals.com).

**Content of this decal set:**

1. Silk Screen printed decals - 3+ sheets
2. Vinyl pre-cut paint masks - 1 pcs.
3. This Manual - 1 pcs.

**PAINT MASKS USAGE SCHEME**

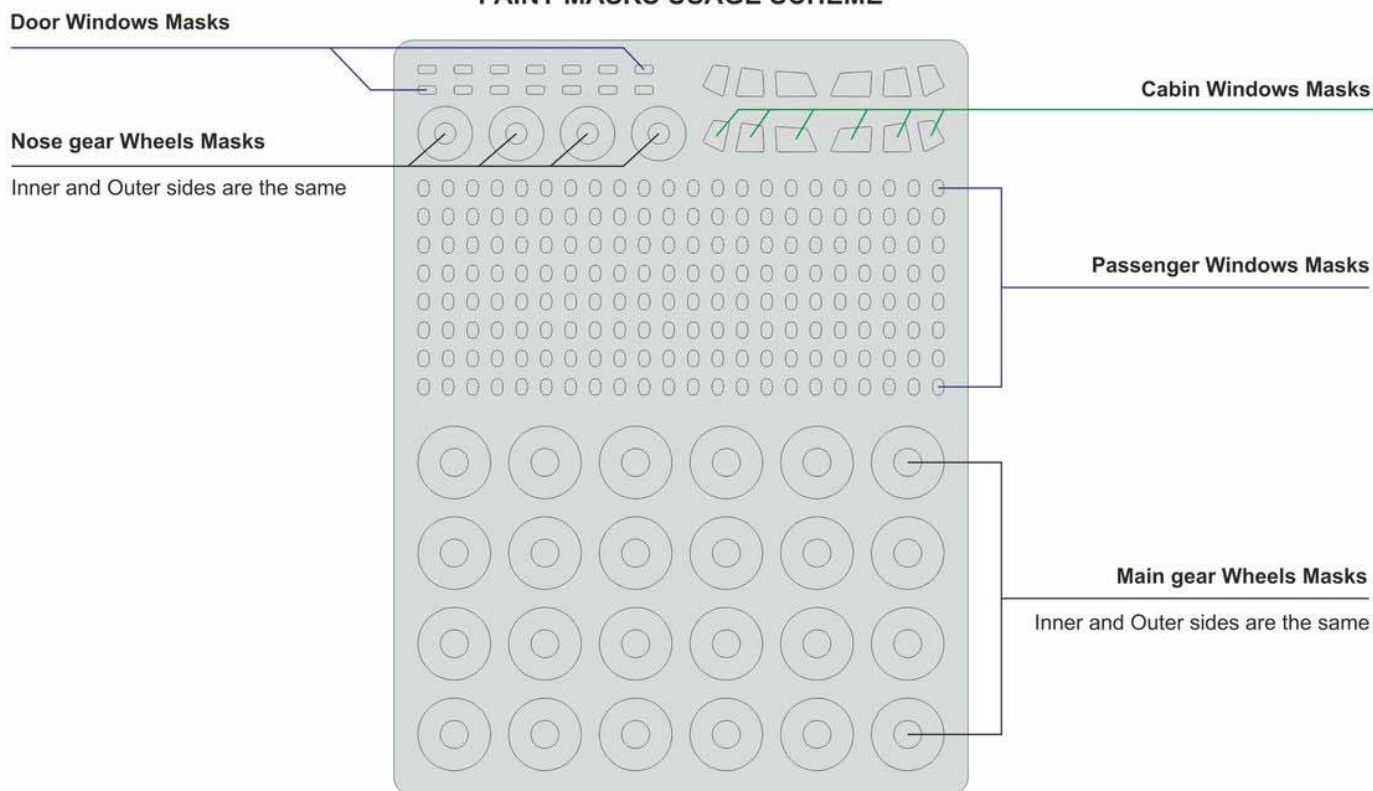

**Model Paint Recommendations:**

The best way to select right colors for your model is choosing colors by photo.

Find photos of your model prototype by registration using most popular websites, such as *airliners.net*, *jetphotos.net*, *planespotters.net* etc.

**Engine cone spiral markings**

Left engine is shown, right one is the same

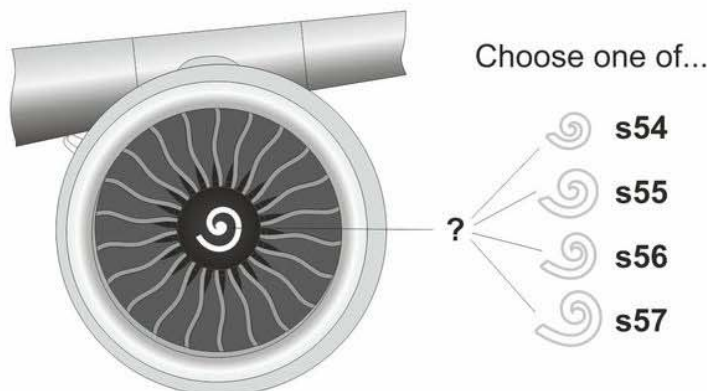

Variant 1. Air China. "Love China". Registration B-2006

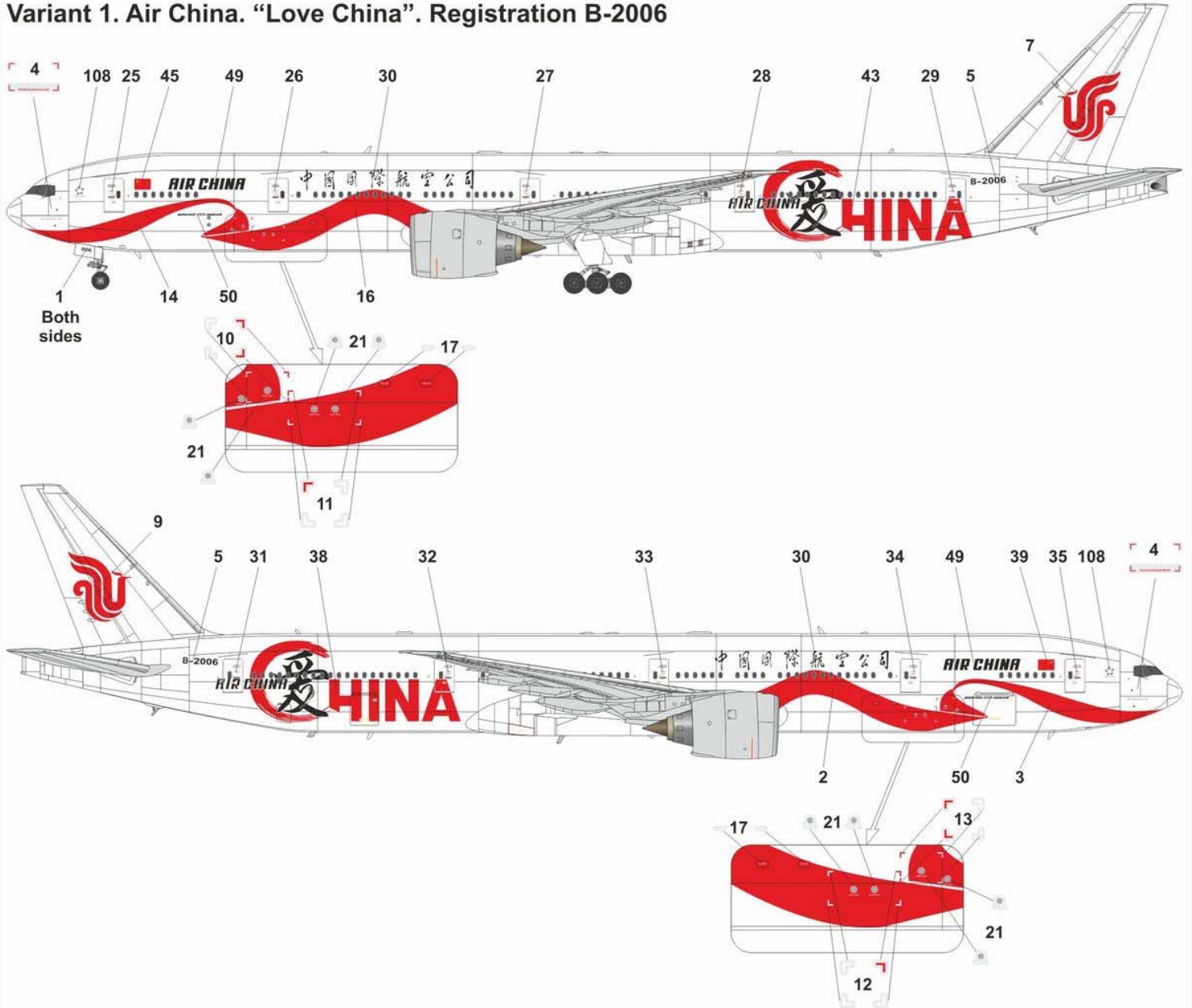

Left wing. Top view.

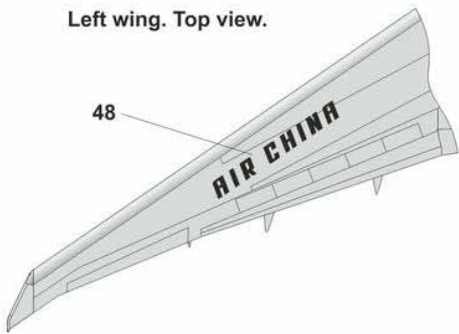

Right wing. Top view.

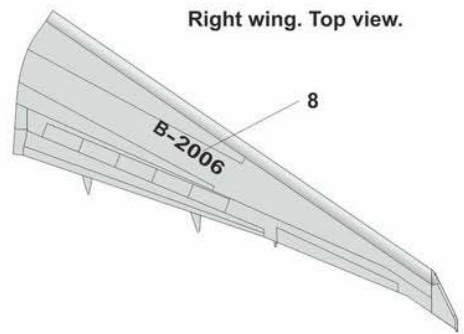

Right wing. Bottom view.

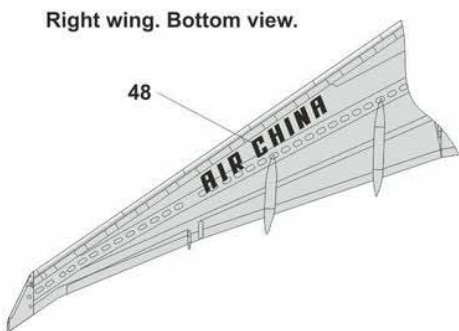

Left wing. Bottom view.

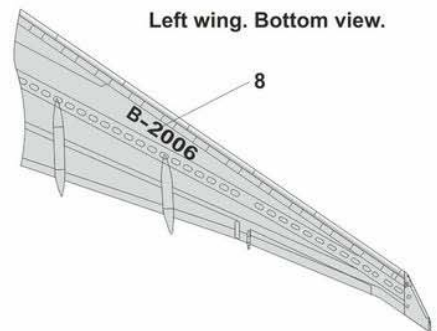

Variant 2. Air China. Registrations B-2086, B-2033, B-2040

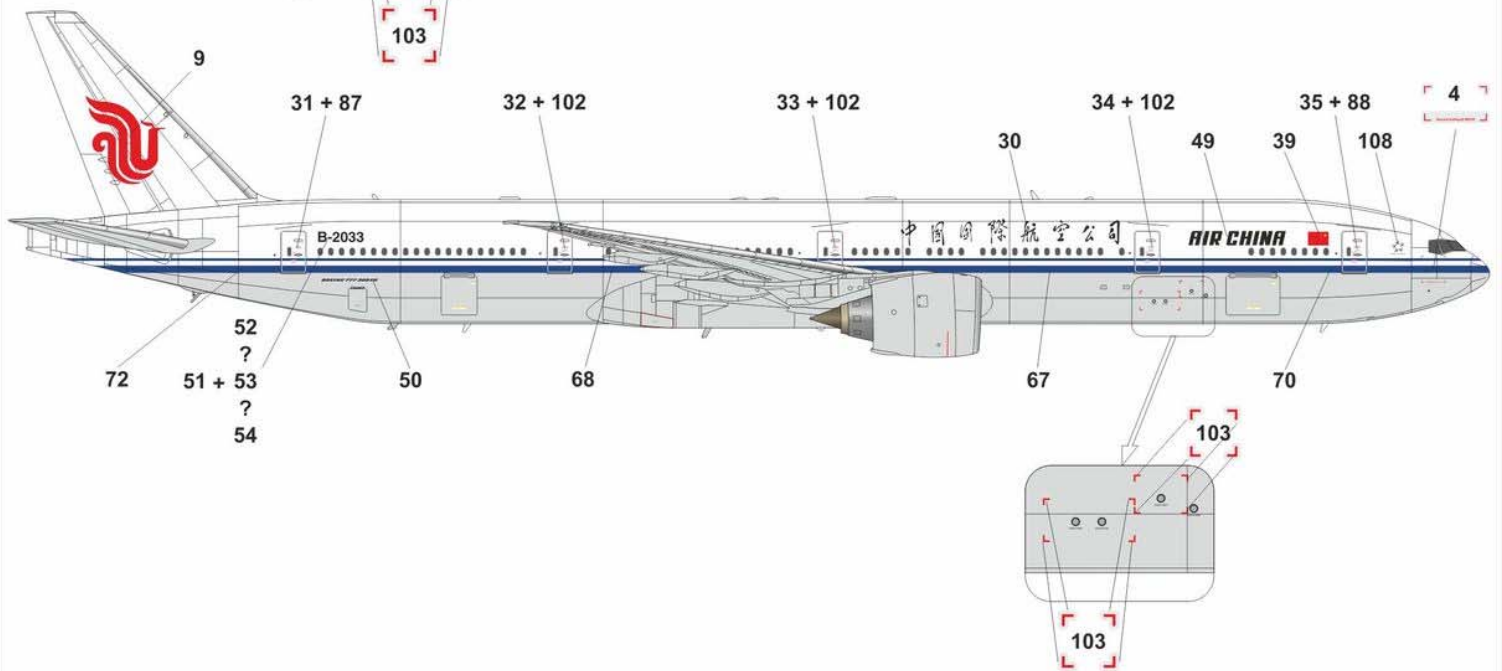
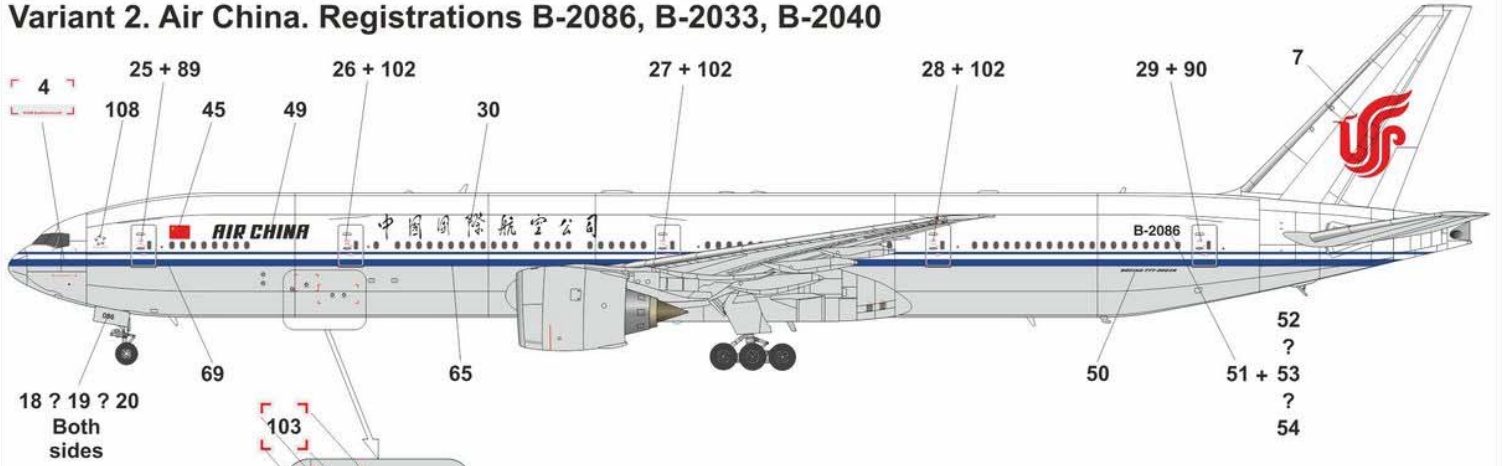

Left wing. Top view.

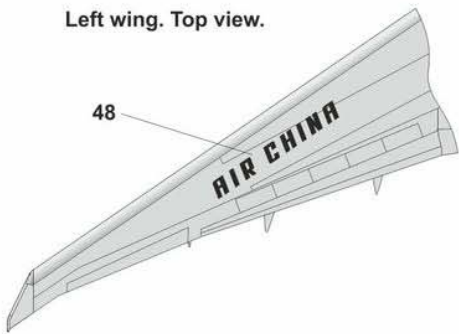

Right wing. Top view.

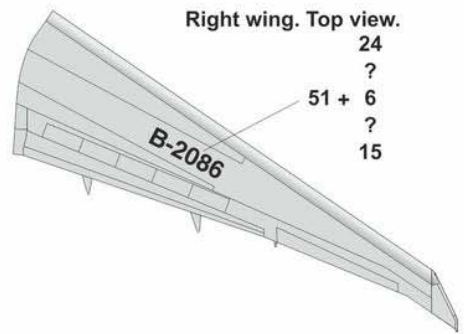

Right wing. Bottom view.

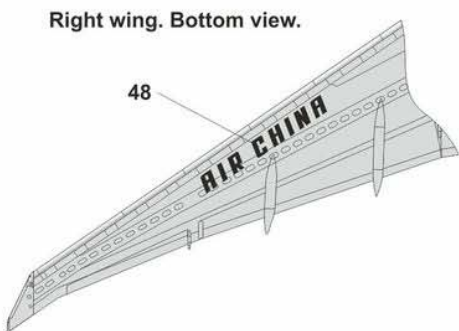

Left wing. Bottom view.

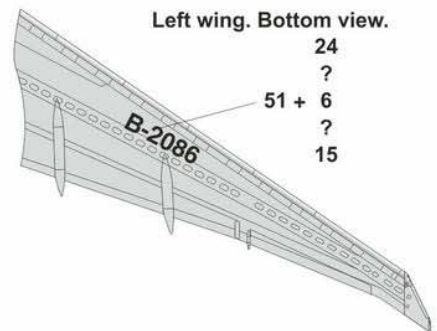

Variant 3. China Eastern Airlines. Registrations B-2001, B-2020

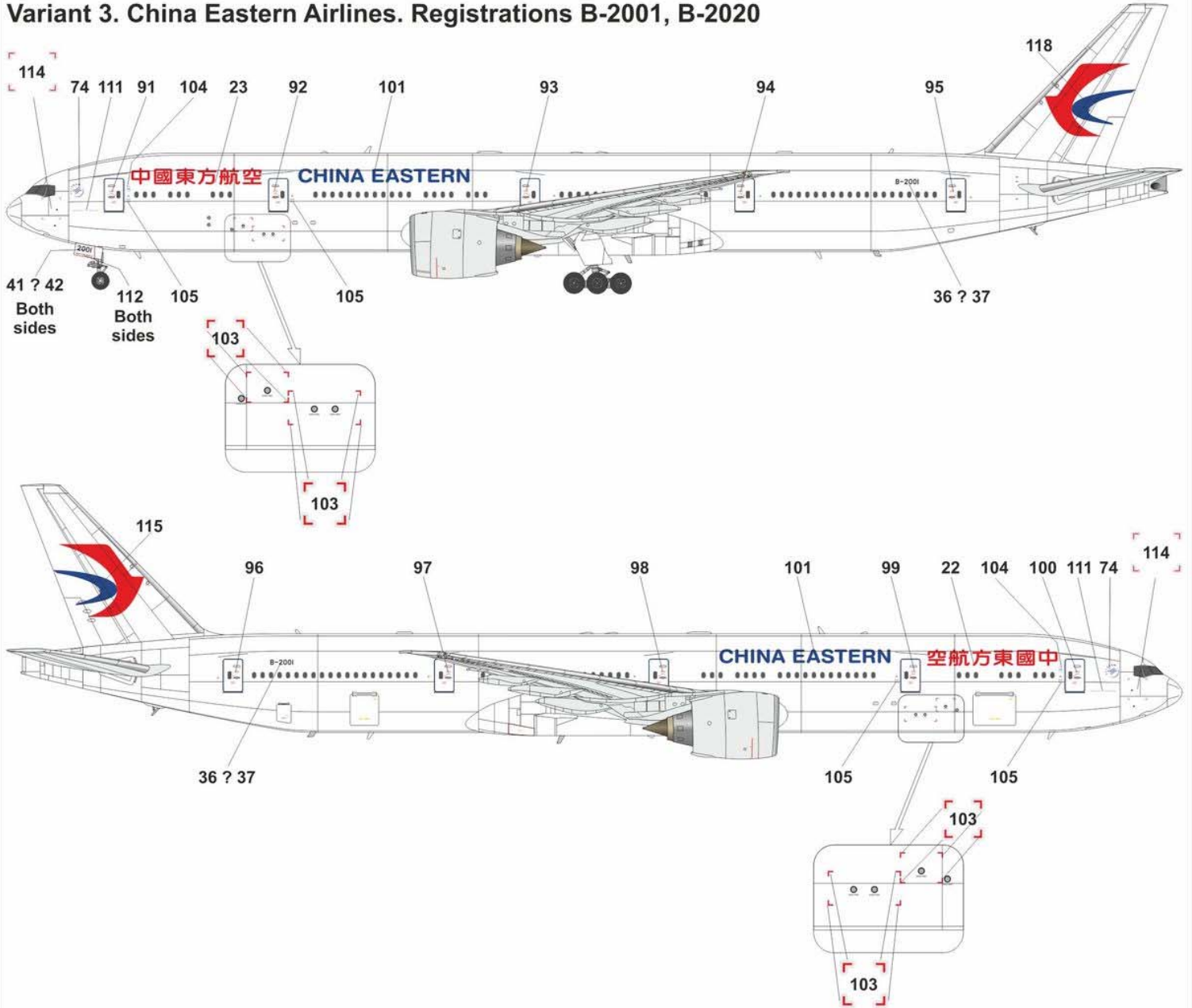

Left wing. Top view.

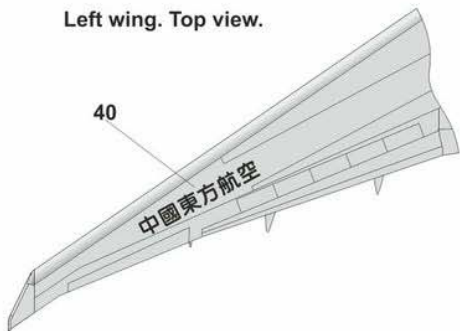

Right wing. Top view.

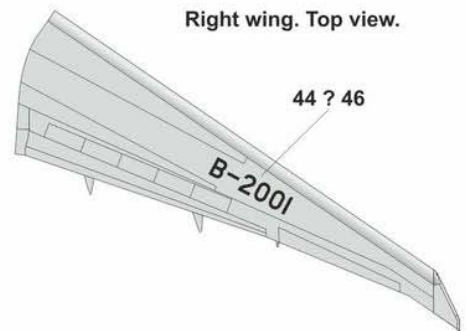

Right wing. Bottom view.

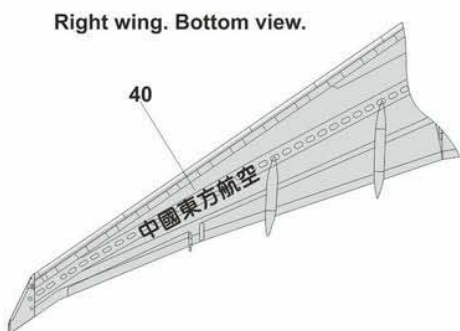

Left wing. Bottom view.

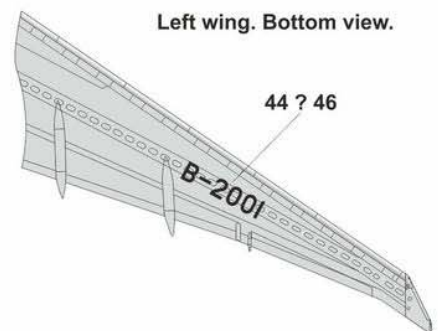

## Variant 4. Korean Air Lines. Registrations HL7782, HL8008, HL8725

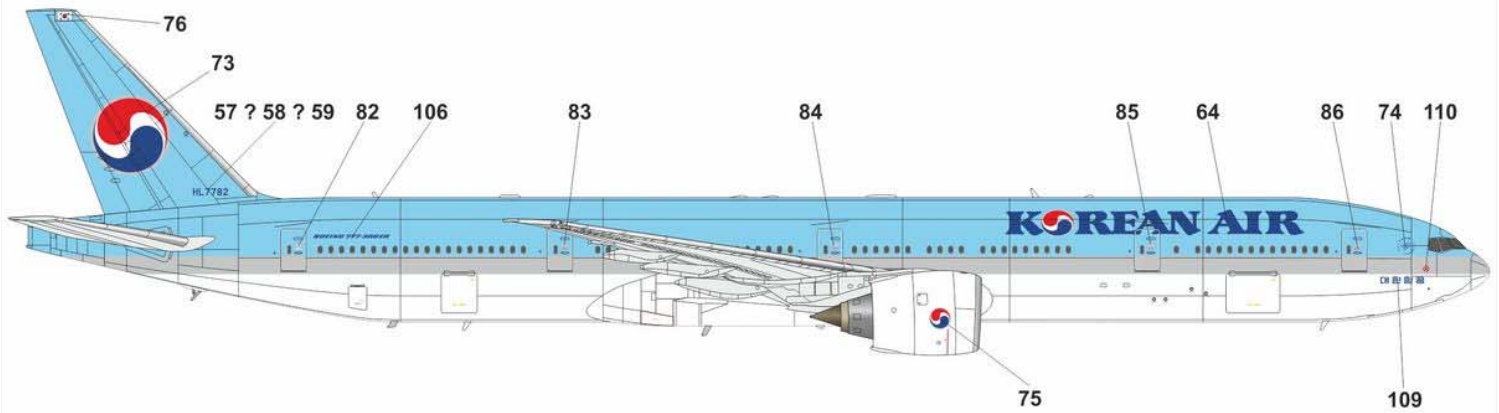
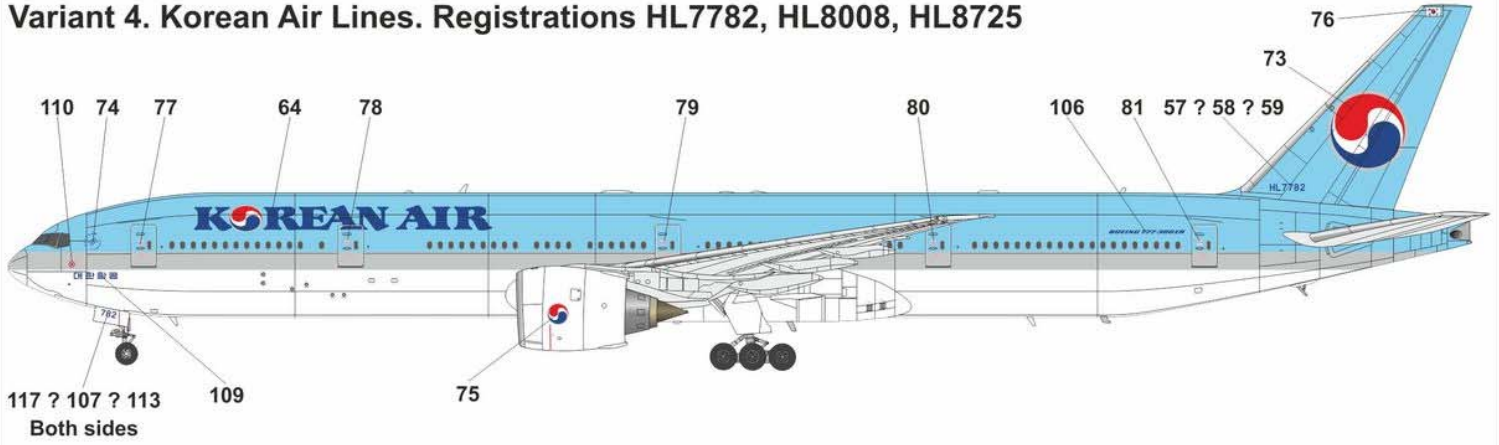

Left wing. Top view.

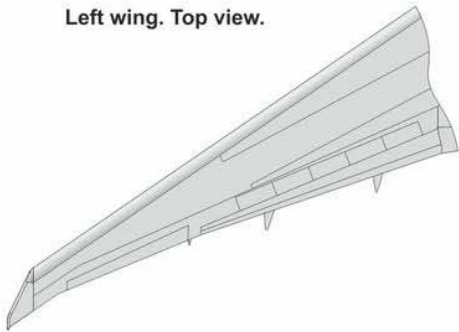

Right wing. Top view.

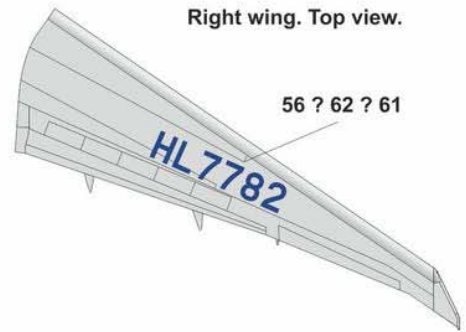

Right wing. Bottom view.

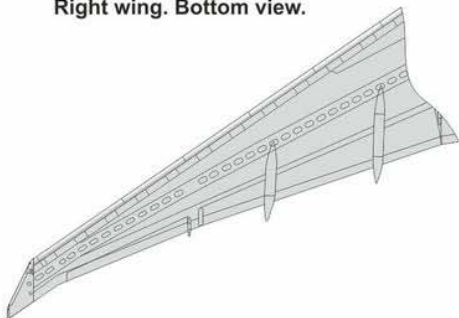

Left wing. Bottom view.

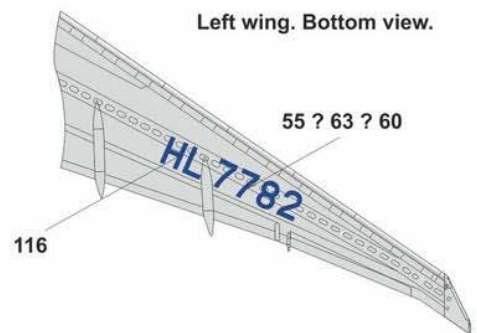

## Technical Stenciling

**NOTE:** The arrow mark “←” near window frames indicate direction to nose.  
You can cut-off unnecessary window frames.

